



Product Description

Odyssey 8500 is the first Broadband Wireless Access (BWA) baseband in the multi-protocol Odyssey family of products. Odyssey 8500 brings wireless IP network connections at broadband speeds to home, work and on the go. It is an all-encompassing System-On-Chip solution integrating Wavesat's software-programmable PHY & CPE MAC engine. Odyssey 8500 facilitates high level of system integration and minimizes the design footprint. Software implementation of the air interface, media access control and communication protocols offer unsurpassed flexibility and a capacity to support multiple communication standards. Odyssey 8500 is fully compliant with 802.16e Wave2 mobile WiMAX profile and its capability extends to other emerging BWA standards such as XG-PHS. It is also the first solution that supports media independent hand-off as defined in IEEE 802.21 standard.

Low Power Consumption

Battery life and heat dissipation continue to challenge the designers and the manufacturers of mobile devices and hinder the capabilities of their products. Odyssey 8500 addresses these challenges through low power consumption and power management. Odyssey 8500 employs voltage scaling and clock frequency tuning to achieve the absolute minimum power consumption for required instantaneous performance. Integrated memory further reduces the total system power resulting in the most power efficient solution available on the market today.

True Mobility Solution

True mobility extends to global roaming and uninterrupted hand-off within the multiple-network environment. Odyssey 8500 is a true mobility solution. It delivers superior radio performance and data rates with 2x2 MIMO support. It also supports WiMAX, WiBro and XG-PHS networks in virtually any frequency band and any channel bandwidth in addition to a seamless network hand-off between BWA and 3G networks such as HSPA or EVDO.

Comprehensive BWA system

Embedded system memory lowers the external device count reducing the system footprint and the total cost of the mobile access terminal. The choice of built-in interfaces is optimized to capture the handset/PDA, USB dongle, Express card and CPE market segments. Odyssey 8500 architecture has been optimized for maximum flexibility while adhering to strict size and cost requirements. Odyssey 8500 is an ideal platform solution for OEMs and ODMs interested in shortening their development cycle for fully standard compliant BWA terminal.

Odyssey 8500

Multiprotocol BWA Baseband

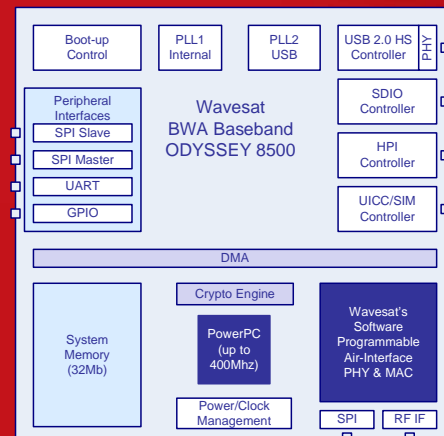

- Fully integrated multiprotocol baseband (PHY & MAC) with Wavesat's Software Programmable Air-Interface Engine
- Low power system with dynamic power management in Active, Idle and Sleep modes
- Embedded System Memory and USB2.0 HS PHY
- WiMAX Wave 2 compliant (MIMO Matrix A & B, beam-forming and H-ARQ)
- Adaptive modulation schemes (up to QAM-256 in DL & UL), up to 1K FFT and advanced FEC techniques
- Enhanced Security Protocol (EAP, AES and PKMv2)
- Multiple packet convergence sub-layers (IPv4, IPv6 & Ethernet) with data packet optimization (PHS, ROHC).
- Remote management SNMP & debug/diagnostic monitor.
- Medium Independent Handover support (MIH, IEEE 802.21) for multi-mode terminals (e.g. 2G, 3G, WiFi)
- Common development platform independent of frequency bands and air interface standards reducing development costs through economies of scale and scope

Mobile Handset System Block Diagram

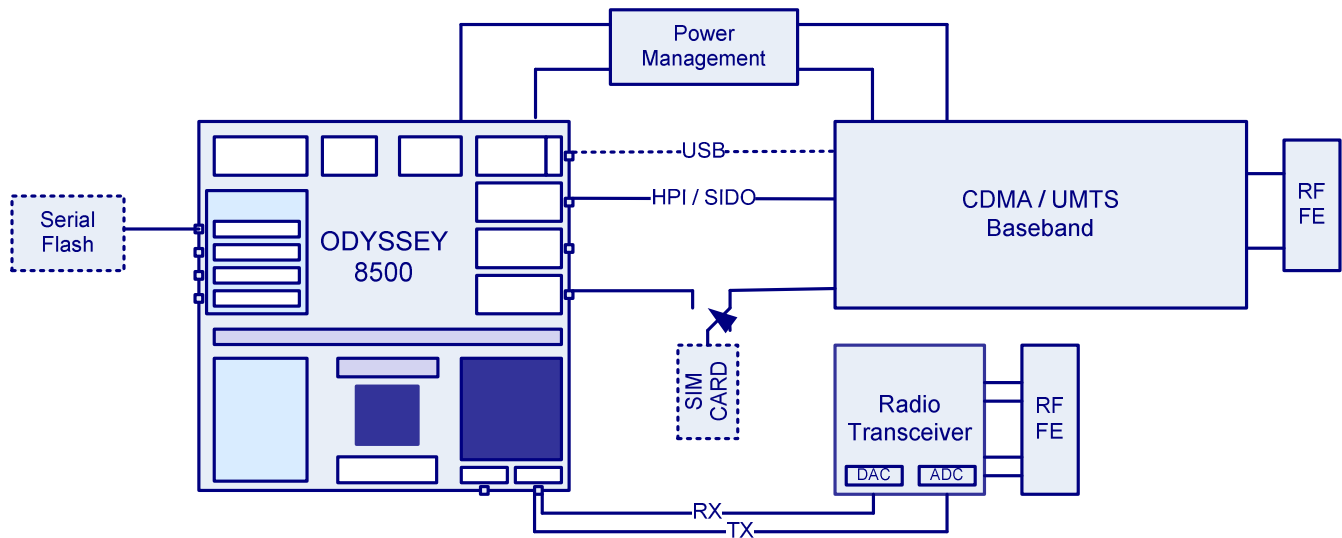

Detailed Specifications

Standard Compliance	IEEE 802.16e-2005, PHS-MOU WG XG-PHS Rel. 2.0
Supported profiles	WiMAX Wave 2 TWG/WiBro & ETWG profiles, XG-PHS
Air Interface PHY	sOFDMA & OFDM; Channel Bandwidth ≤ 20 MHz; FFT 64, 128, 256, 512 & 1024; BPSK, QPSK, 16-QAM, 64-QAM & 256-QAM; TDD & H-FDD
Embedded Processor & Memory	Power PC PPC405 (scalable frequency up to 400MHz), 32 Mb eDRAM
RF Transceiver Interface	JEDEC JESD-207 Digital Interface
System Interfaces	USB 2.0 High Speed, SDIO, HPI, SIM/SmartCard/UICC, SPI, GPIO
Reference Clock Input	12-60 MHz
Package	12mm x 12mm BGA (177 pins, 0.65mm pitch)
Operating Temperature	Commercial: 0 - 70°C, Industrial: 0 - 85°C, Extended: -40° - 85°C
Power Consumption	<150mW in receiving mode ¹ and <2mW in Idle mode

Ordering Information

OD-8500-IC-CMT	Odyssey 8500 Multiprotocol BWA Baseband, Commercial Temperature
OD-8500-IC-IDT	Odyssey 8500 Multiprotocol BWA Baseband, Industrial Temperature
OD-8500-IC-EXT	Odyssey 8500 Multiprotocol BWA Baseband, Extended Temperature
OD-8500-EK	Odyssey 8500 Evaluation Kit
OD-8500-DK	Odyssey 8500 Development Kit
Odyssey family of products also includes reference design kits (RK) for turn-key solutions in multiple form factors (USB dongle, ExpressCard, PCI Express MiniCard). Consult separate product brief for detailed information	

Specifications are subject to change without notice

¹ Excluding DRAM

